

# CATALYTIC HEATER / CHAUFFAGE CATALYTIQUE : ELZO 3000 THERMO

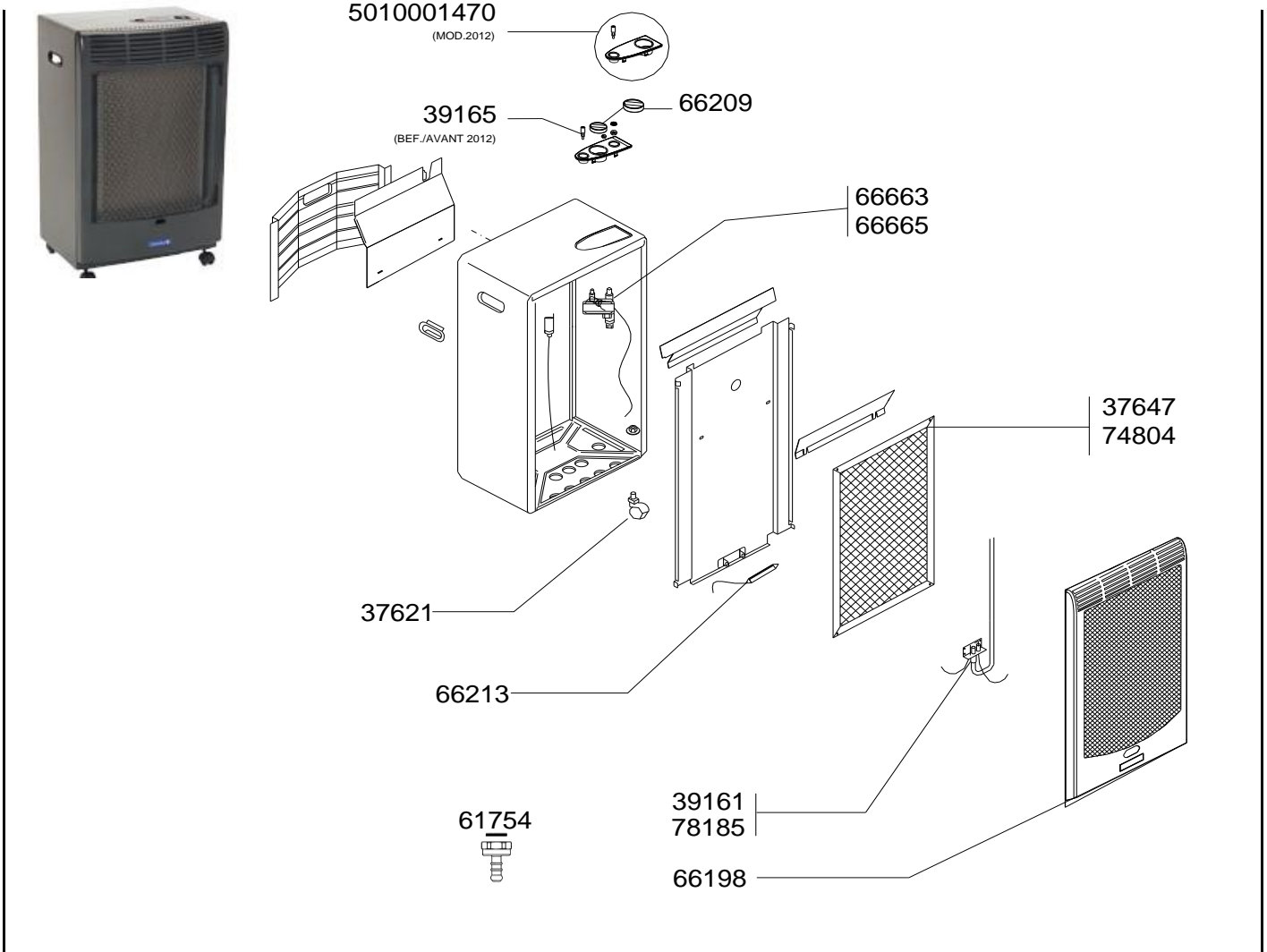

REF.	POINTS	- GB - DESIGNATIONS	DESIGNATIONS - F -
37621	50	WHEEL (X2)	ROUE (X2)
37647	340	CATALYTIC PANEL (MOD.BEFORE 2006)	PANNEAU CATALYTIQUE (MOD.AVANT 2006)
39161	150	GAS STOP DEVICE (FOR MALE CONNECTOR)	VEILLEUSE + THERMOCOUPLE (POUR RACCORD MALE)
39165	50	PIEZO IGNITER (BEFORE 2012)	PIEZO (AVANT 2012)
61754	50	SCREWED ADAPTATOR + WASHER	ADAPTATEUR TETINE VISSE +JOINT
66198	175	FRONT PANEL - BLUE	FACADE AVANT BLEUE
66209	30	THERMOSTAT SWITCH	VOLANT DE THERMOSTAT
66213	270	THERMOSTAT	THERMOSTAT
66663	30	JET	INJECTEUR
66665	170	SAFETY VALVE	VANNE DE SECURITE
71169	50	UPPER POLYSTYRENE WEDGE	CALE POLYSTYRENE SUPERIEURE
71171	50	LOWER POLYSTYRENE WEDGE	CALE POLYSTYRENE INFERIEURE
74804	320	CATALYTIC PANEL WITH ELBOW NOZZLE	PANNEAU CATALYTIQUE AVEC RACCORD COUDE
78185	150	GAS STOP DEVICE (FOR FEMALE CONNECTOR)	VEILLEUSE & THERMOCOUPLE (POUR RACCORD FEMELLE)
5010001470	50	PIEZO IGNITER (MOD.2012)	PIEZO (MOD.2012)
79884	70	PACKAGING MOD.2008	EMBALLAGE MOD.2008