

**UNLEADED FUEL  
COMPACT LANTERN (226)  
LAMPE COMPACTE A ESSENCE**

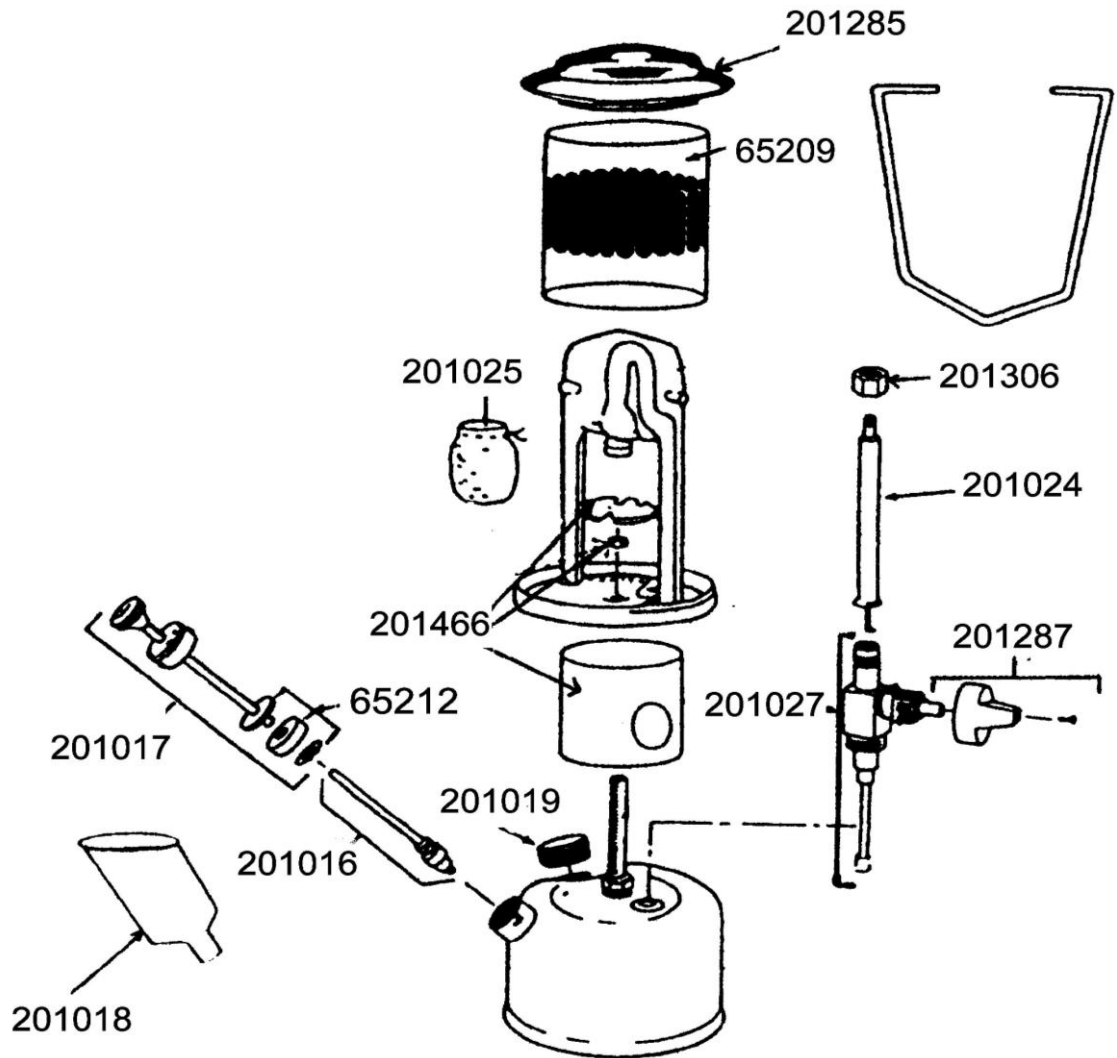

REF.	POINTS	GB DESIGNATIONS	DESIGNATIONS F
65209	100	GLOBE DIAMETER 80	VERRE DIAMETRE 80
65212	80	PUMP CUP & CLIP (BLISTER PKG)	JOINT PISTON POMPE (BLISTER)
201016	50	AIR STEM & CHECK VALVE	ENSEMBLE CLAPET DE RETENUE
201017	70	PUMP PLUNGER CURRENT MODEL	PLONGEUR DE POMPE MOD. ACTUEL
201018	60	FILTER FUNNEL	ENTONNOIR
201019	70	FILLER CAP	BOUCHON DE REMPLISSAGE
201024	100	GENERATOR	GENERATEUR
201025	40	MANTLE (X2)	MANCHON (X2)
201027	160	VALVE ASSEMBLY	ROBINET
201285	170	CAP	CHAPEAU
201287	60	KNOB & SCREW	VOLANT ROBINET & VIS
201306	30	JAMB NUT	ECROU FIXATION