

**DUAL FUEL POWERHOUSE 2  
MANTLE LANTERN (295)  
LANTERNE ESSENCE 2 MANCHONS**

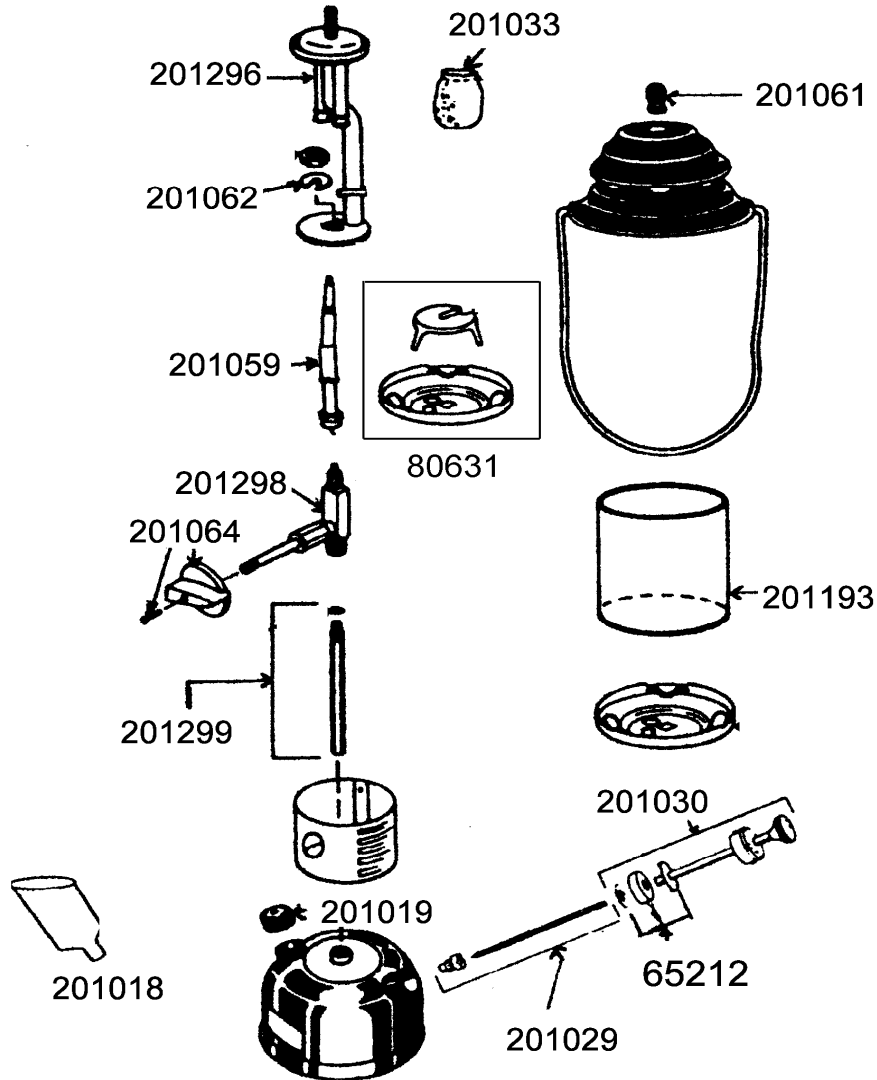

REF.	POINTS	GB DESIGNATIONS	DESIGNATIONS F
65212	80	PUMP CUP & CLIP (BLISTER PKG)	JOINT PISTON POMPE (BLISTER)
80631	110	HEAT SHIELD + FRAME BOTTOM	PARE CHALEUR + CAGE
201018	60	FILTER FUNNEL	ENTONNOIR
201019	70	FILLER CAP	BOUCHON DE REMPLISSAGE
201029	50	AIR STEM & CHECK VALVE	ENSEMBLE CLAPET DE RETENUE
201030	100	PUMP PLUNGER (OLD&CURRENT MOD)	PLONGEUR POMPE(ANCIEN&ACTUEL)
201033	45	MANTLE (X2)	MANCHON (X2)
201059	110	GENERATOR	GENERATEUR
201061	50	CAP SCREW (X2)	ECROU CHAPEAU (X2)
201062	40	U CLIP	ATTACHE EN U
201064	50	KNOB & SCREW	VOLANT & VIS
201193	130	GLOBE DIAM.125	VERRE DIAM 125
201296	170	BURNER ASSEMBLY	ENSEMBLE BRULEUR
201298	90	VALVE	ROBINET
201299	50	FEED TUBE ASSEMBLY	ENSEMBLE TUBE ALIMENTATION