

# LANTERNS / LANTERNES : F1 LITE

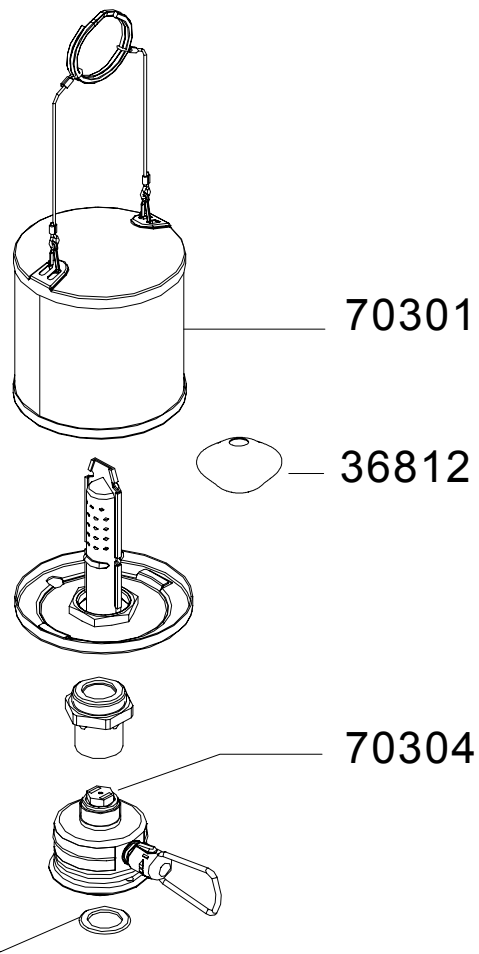

REF.	POINTS	GB DESIGNATIONS	DESIGNATIONS F
36812	40	ACCESSORY MANTLE SIZE S (X 3)	ACCESSOIRE MANCHON TAILLE S (X3)
70301	50	MESH GLOBE	CAGE COMPLETE
70304	60	JET	INJECTEUR
201229	30	O RING (X2)	JOINT TORIQUE POUSSE VALVE X2